

Off-line Oil Filter Module

Pi 8400

Volume flow 3 l/min

1. Features

Compact, ready-to connect oil filter module for modern hydraulic and lubrication systems

- Low noise internal gear pump
- Minimum loss of performance due to the high efficiency and the volume flow optimised design of parts
- Integrated pressure relieve valve
- Visual maintenance indicator (gauge)
- Drain outlet dirt side
- Equipped with highly efficient Filtration Group Premium Select filter elements
- Compact and weight optimised design
- Guaranteed retention rates according to ISO 16889 multipass test
- High dirt holding capacity due to the large filter surface
- Defined cleanliness classes according to ISO 4406
- Easy to service
- Worldwide sales and service



2. Mode of operation

The oil filter module consists of an electric motor, a gear pump, a filter housing and a filter element.

The internal-gear pump is extremely quiet and virtually vibration-free, with excellent suction capacity and sophisticated mechanical and volumetric efficiencies.

Two versions of the oil filter modul are available. Type Pi 84001/1-063 is fitted with standard DIN-norm elements. Type 84001/2-063 is fitted with Filtration Group designed elements 852 109 WS. These elements have the additional characteristics of water adsorption. 852 109 WS elements do not fit into Pi 84001/1-063 housings.

Usually 10 micron filtration is being used in the main filtration circuit. Therefore we recommend a 3 micron retention rate at the off-line circuit. Other degrees of filtration are available on request. All retention rates are according to ISO 16889.

In bypass mode, superior oil cleanliness codes per ISO 4406 of up to 14/12/09 and better can be achieved with these filter units and the Filtration Group PS filter elements.

For monitoring the filter element, a gauge is mounted. The oil filter modules are suitable for all mineral-oil-based hydraulic oils and lubricating oils.

Units are available for prompt delivery

3. Flow rate/pressure drop curve (filter housing incl. element)

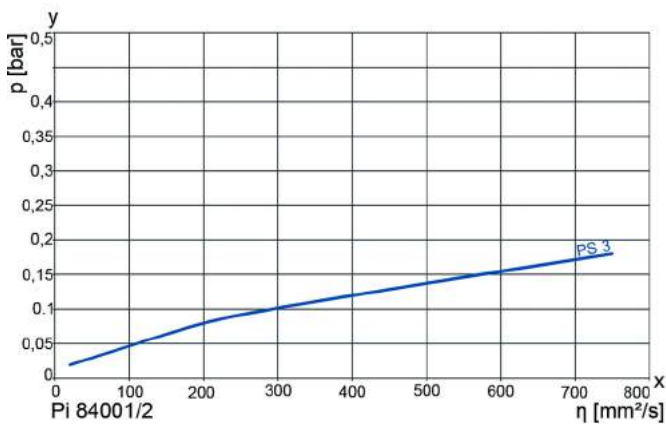

y = pressure p [bar]
x = viscosity [mm²/s]

A wider range of grade of filtration on request.

4. Separation grade characteristics

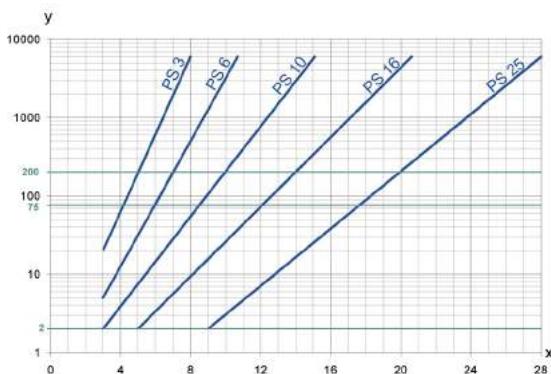

y = beta-value
x = particle size [μm]

determined by multipass tests (ISO 16889)
calibration according to ISO 11171 (NIST)

5. Filter performance data

tested according to ISO 16889 (Multipass-Test)

PS elements with max. Δp 10 bar

PS	3	$\beta_{5(C)} \geq 200$
PS	6	$\beta_{7(C)} \geq 200$
PS	10	$\beta_{10(C)} \geq 200$
PS	16	$\beta_{15(C)} \geq 200$
PS	25	$\beta_{20(C)} \geq 200$

6. Quality assurance

Filtration Group filters and filter elements are produced according to the following international standards:

Norm	Designation
DIN ISO 2941	Hydraulic fluid power filter elements; verification of collapse/burst resistance
DIN ISO 2942	Hydraulic fluid power filter elements; verification of fabrication integrity
DIN ISO 2943	Hydraulic fluid power filter elements; verification of material compatibility with fluids
DIN ISO 3723	Hydraulic fluid power filter elements; method for end load test
DIN ISO 3724	Hydraulic fluid power filter elements; verification of flow fatigue characteristics
ISO 3968	Hydraulic fluid power-filters-evaluation of pressure drop versus flow characteristics
ISO 10771.1	Fatigue pressure testing of metal containing envelopes in hydraulic fluid applications
ISO 16889	Hydraulic fluid power filters-multipass method for evaluation filtration performance of a filter element

7. Symbols

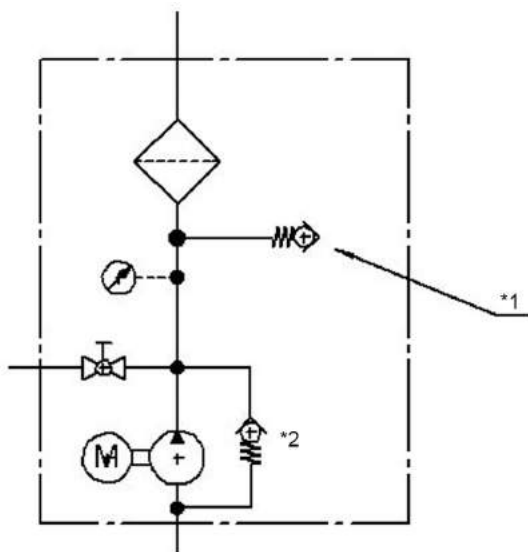

*1 measuring connection available

*2 pressure relieve valve 4.8 bar (70 psi) ± 10 %

8. Order numbers

Example for ordering filters:

1. Off-line oil filter module	2. Filter element
with gauge Type: Pi 84001/1-063 Order number: 70562951	PS 10 Type: Pi 23025 PS 10 Order number: 77924160

8.1 Off-line oil filter module		
Type	Order number	with gauge
Pi 84001/1-063	70562951	
Pi 84001/2-063	70562883	

8.2 Filter elements

Off-line oil filter module	Order number	Type	Degree of filtration [µm]	Filter surface [cm ²]
Pi 84001/1-063	77924152	Pi 21025 RN PS 3	3	5940
	77964075	Pi 22025 RN PS 6	6	5940
	77924160	Pi 23025 RN PS 10	10	5940
	77963655	Pi 24025 RN PS 16	16	5940
	77960248	Pi 25025 RN PS 25	25	5940
Pi 84001/2-063	70566180	852 109 WS PS 3	3	10.507

9. Technical specifications

Type:	Pi 8400
Material main components:	Aluminium
	Optional paint on customer request
Volume flow:	3 l/min
Nominal pressure:	10 bar (145 psi)
Pressure relieve valve setting:	4.8 bar (70 psi) ± 10 %
Oil temperature:	-10 °C to +80 °C
Gauge (red/green scale):	2.2 bar (32 psi)
Connection suction side:	G3/8
Connection pressure side:	G3/8
Motor output:	0.18 kW
Revolutions:	1380 1/min
Voltage:	230 V AC/50 Hz
Nominal current:	1,25 A
Type of protection:	IP55
Viscosity start:	700 mm ² /s
Viscosity operation:	20 mm ² /s - 120 mm ² /s

Other motor versions on request

Subject to technical alteration without prior notice

10. Dimensions

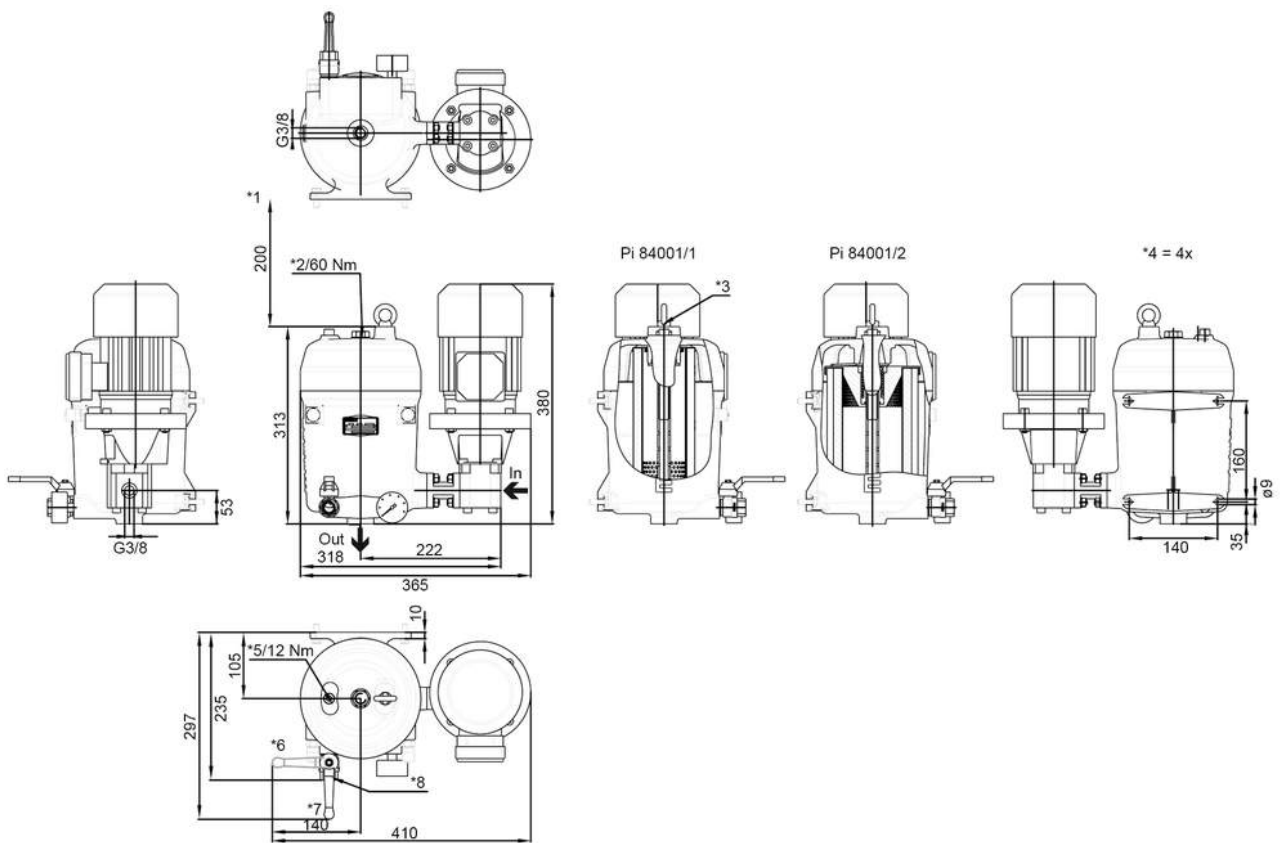

In	Inlet
Out	Outlet
*1	Minimum clearance for filter element
*2	Cover fixing (60 Nm)
*3	Connection maintenance indicator (optional)

*4	Fixing points (4x \varnothing 9 mm)
*5	Venting screw (12 Nm)
*6	Ball valve drain dirt side closed
*7	Ball valve drain dirt side open
*8	Drain dirt side

11. Installation, operating and maintenance instructions

11.1 Off-line oil filter module installation

When installing the filter make sure that sufficient space is available to remove filter element. The filter must be installed with the filter housing pointing upwards. The gauge must be visible.

11.2 When should the filter element be replaced?

1. The filter element should be replaced after the trial run or flushing of the system. Afterwards follow instructions of the manufacturer.
2. Please always ensure that you have original Filtration Group spare elements in stock: Disposable elements (PS) cannot be cleaned.

11.3 Element replacement

1. Stop system and relieve filter module from pressure.
2. Unscrew the cover with an open-end wrench and remove it.
3. Open the drain and discharge the housing completely.
4. Remove element out of the housing carefully.
5. Check seals on the filter housing for damage. Replace, if necessary.
6. Make sure that the order number on the spare element corresponds to the order number of the filter name-plate. To ensure no contamination occurs during the exchange of the element first open the plastic bag and push the element over the spigot in the filter head. Now remove plastic bag.
7. Close the drain.
8. Tighten the cover (tightening torque 60 Nm).
9. Vent the filter module (tightening torque of the venting screw 12 Nm).

12. Spare parts list

Pi 84001/1

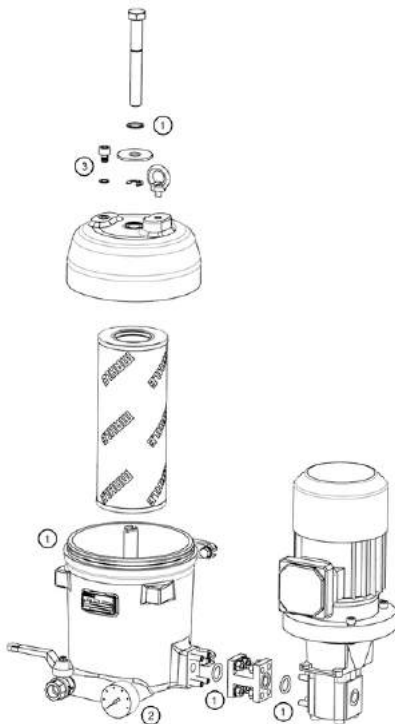

Pi 84001/2

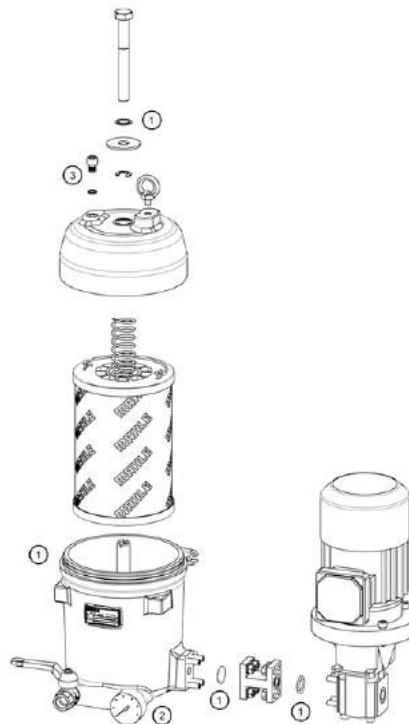

Order numbers for spare parts

Position	Type	Order number
①	Seal kit	70560114
②	Gauge	78381998
③	Venting screw incl. seal	70560152

Filtration Group GmbH
 Schleifbachweg 45
 D-74613 Öhringen
 Phone +49 7941 6466-0
 Fax +49 7941 6466-429
 sales@filtrationgroup.com
 www.filtrationgroup.com
 70564541.12/2016